

LARIO 2

	Capacity	Delivery	Connection	Suction
	l/min	m		m
2	35	30	1"gas	8
3	50	30	1"1/4gas	8
4	70	30	1"1/2gas	8
5	100	30	2"gas	8

Sito Web



Catalogo Generale



Feit Pompe S.r.l.

Via Venezia, 34/g - 10088 - Volpiano (TO) - ITALIA

Tel: +39 (0)11 9884327 - info@feit.srl - feit.srl

FEIT
1946
Evolving with you...

CHARACTERISTICS

- **(B):** bronze
- Immediate self-priming without need for pre-filling pump body
- Maximum reliability of operation, even following inactivity for lengthy periods
- **(G):** cast iron
- Requires no foot valve, or filter
- No maintenance required
- Easy to disassemble

APPLICATIONS

- seawater, bilge of amphibian vehicles and crafts
- decanting fuels usually: petrol, diesel, kerosene, oil, naphtha, fluid oils, etc.
- draining of basements, underground passages, drains for electrical and phone cables
- draining wells of fuel distributors

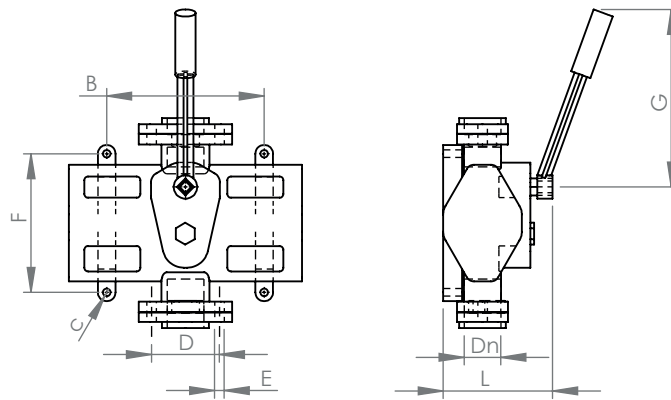

	F	A	B	C	D	E	F	G	H	I	L	Kg
2	1"	280	185	11	64	9	132	270	170	39	130	8
3	1 1/4"	210	210	13	74	9	165	330	200	45	165	11
4	1 1/2"	370	250	13	85	9	190	500	250	50	190	15
5	2"	480	340	13	85	9	220	500	260	65	220	23

Sito Web



Catalogo Generale



Feit Pompe S.r.l.

Via Venezia, 34/g - 10088 - Volpiano (TO) - ITALIA

Tel: +39 (0)11 9884327 - info@feit.srl - feit.srl

FEIT
1946
Evolving with you...