

EXCELSIOR 1G/B

	Capacity l/min	Delivery m	Connection	Suction m
0	16	15	1/2"gas	7
1	20	20	3/4"gas	7
2	30	20	1"gas	8
3	40	20	1"1/4gas	8
4	55	20	1"1/4gas	8
5	80	20	1"1/2 gas	8

Sito Web



Catalogo Generale



**Feit Pompe S.r.l.**

Via Venezia, 34/g - 10088 - Volpiano (TO) - ITALIA

Tel: +39 (0)11 9884327 - info@feit.srl - feit.srl

**FEIT**  
1946  
Evolving with you...

## CHARACTERISTICS

- **(B)**: bronze
- **(G)**: cast iron

## APPLICATIONS

- seawater, bilge of amphibian vehicles and crafts
- decanting fuels usually: petrol, diesel, kerosene, oil, naphtha, fluid oils, etc.
- draining of basements, underground passages, drains for electrical and phone cables
- draining wells of fuel distributors

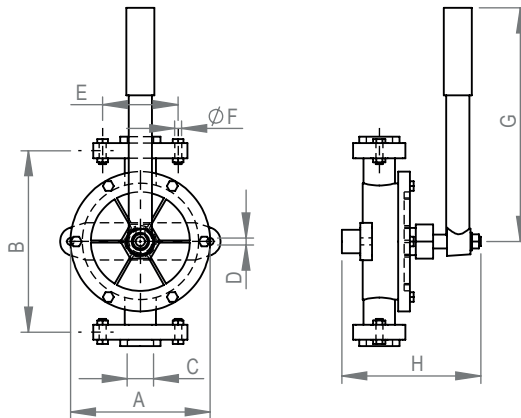

	A	B	C	D	E	F	G	H	Kg
<b>0</b>	125	175	1/2"	9	43	7	260	136	3,3
<b>1</b>	150	205	3/4"	11	55	7	260	136	4,5
<b>2</b>	170	230	1"	12	64	9	260	138	5,5
<b>3</b>	190	260	1"1/4	12	74	9	320	166	8,3
<b>4</b>	220	285	1"1/4	12	74	9	410	185	10
<b>5</b>	250	320	1"1/2	15	85	9	410	185	13

Sito Web



Catalogo Generale



**Feit Pompe S.r.l.**  
Via Venezia, 34/g - 10088 - Volpiano (TO) - ITALIA  
Tel: +39 (0)11 9884327 - info@feit.srl - feit.srl

**FEIT**  
1946  
Evolving with you...